







-688396- 2020-07-29  
-688396- 2020-04-24 IDM

0755-81981821  
E-MAIL ouyangsh1@guosen.com.cn  
S0980517080002

0755-81981025  
E-MAIL xuliang1@guosen.com.cn  
S0980518120001

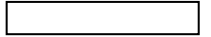



---

1983

IDM

MOSFET PMIC

HIS Markit 2018



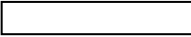

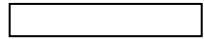



18 Infineon

19 Infineon

21 On Semi

22 On Semi

23 On Semi 2020

24 On Semi

25

26

27 2019

28

32

33

34 IC IC

35

36

37

38

39

40



---

41 IC  
42  
43

51  
52

54  
55

---



	2017	2018	2019	2020E	2021E	2022E	2023E	2024E	2025E
	33.63%	6.73%	-8.42%	17.41%	11.41%	12.40%	15.00%	15.00%	15.00%
/	82.38%	74.80%	77.16%	73.66%	73.63%	73.65%	73.65%	73.65%	73.65%
/	5.55%	5.56%	6.03%	2.0%	2.0%	2.0%	2.00%	2.00%	2.00%
/	2.04%	2.01%	1.95%	2.0%	2.0%	2.0%	2.00%	2.00%	2.00%
/	1.34%	1.35%	1.15%	1.00%	1.00%	1.00%	1.00%	1.00%	1.00%
	-75.43%	8.98%	-1.28%	0.00%	0.00%	0.00%	0.00%	0.00%	0.00%
	7.32%	29.81%	38.70%	30.00%	30.00%	30.00%	30.00%	30.00%	30.00%

Beta	0.8	T	7.00%
	2.50%	Ka	4.90%
	3.00%	Beta	0.84
	48.17	Ke	5.01%
	1216	E/(D+E)	100.00%
(E )	58571	D/(D+E)	0.00%
(D )	2752	WACC	5.00%



---

Kd	5.30%		10	2.00%
----	-------	--	----	-------

---

---

	WACC				
	4.0%	4.5%	5.0%	5.5%	6.0%

---



IDM

IC

MOSFET PMIC

MOSFET PMIC

MOSFET PMIC

MOSFET+PMIC

1

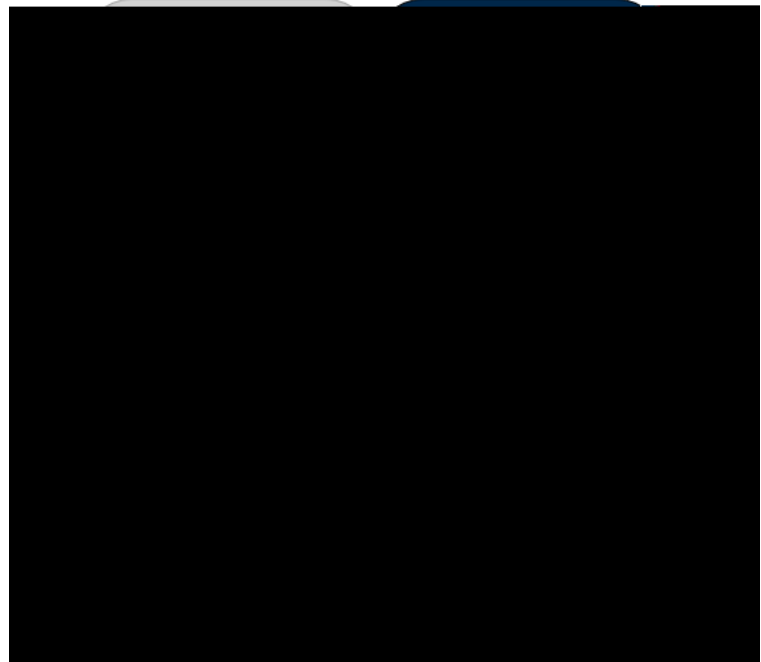

30 +

1983

4

1999

6 MOS

6

8

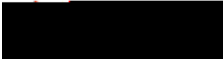

2

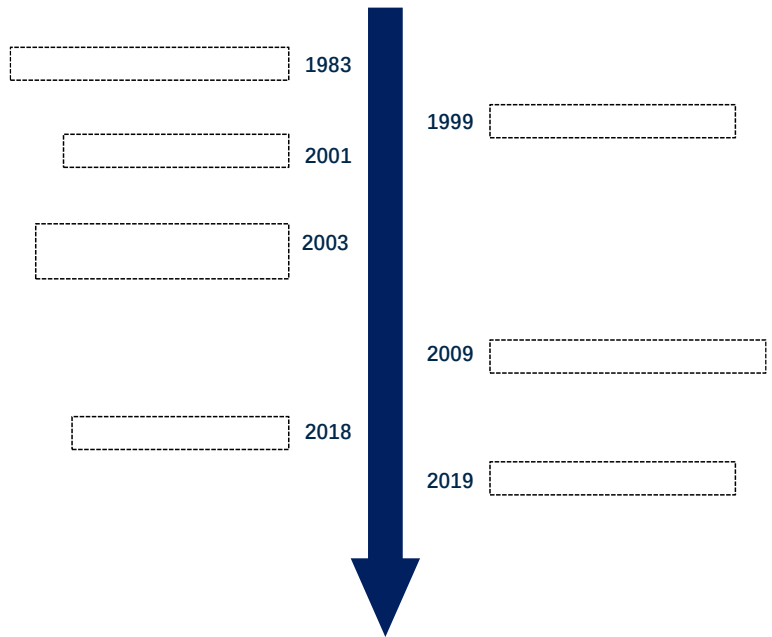

2002

2008

2017

2019

35%

3

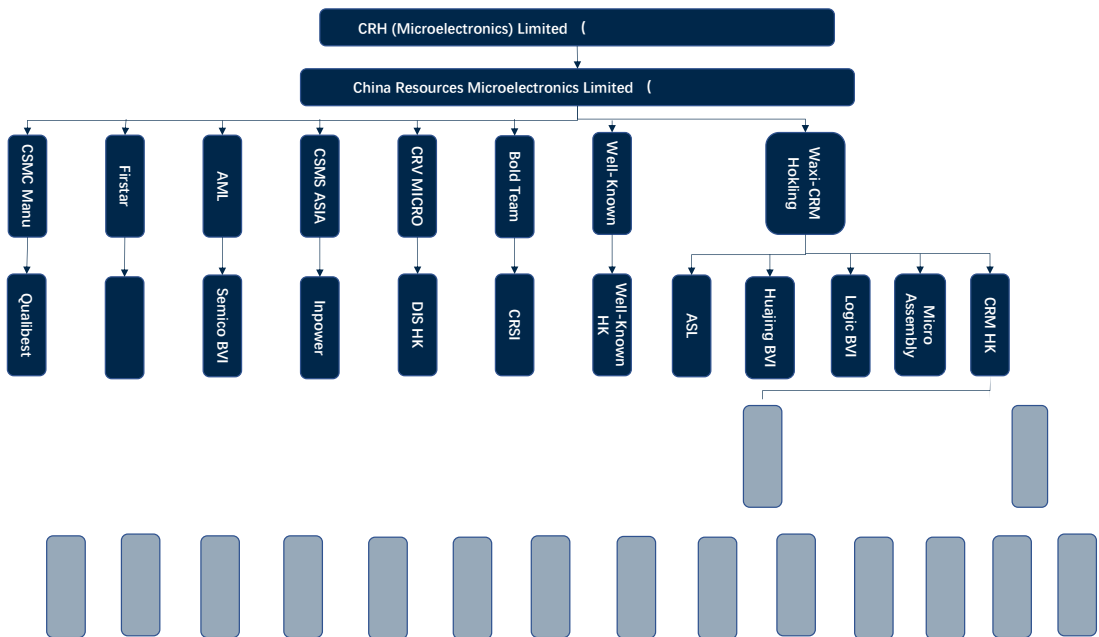



---

Infineon

ON

---

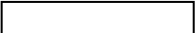
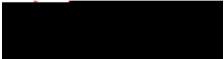

5 MOSFET

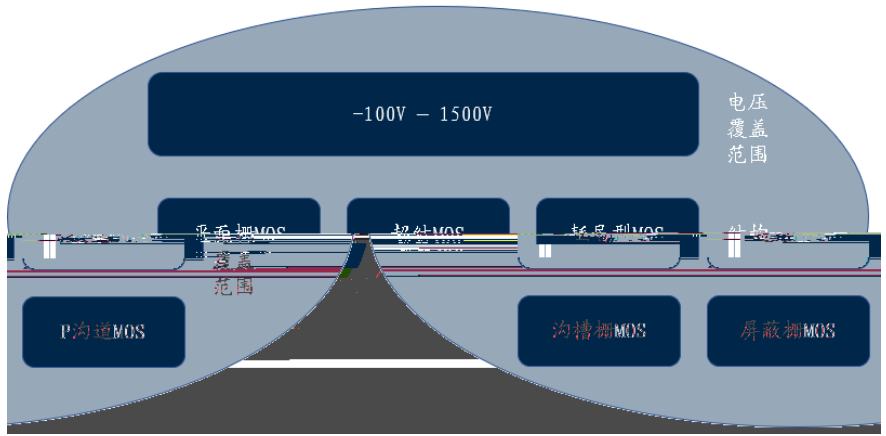

6

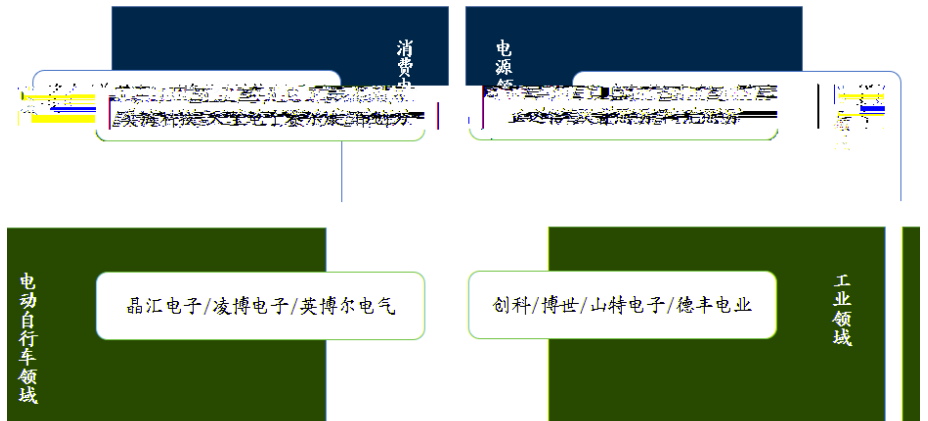

MPS

Diodes Incorporated

2016-2019

20%

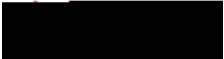

7

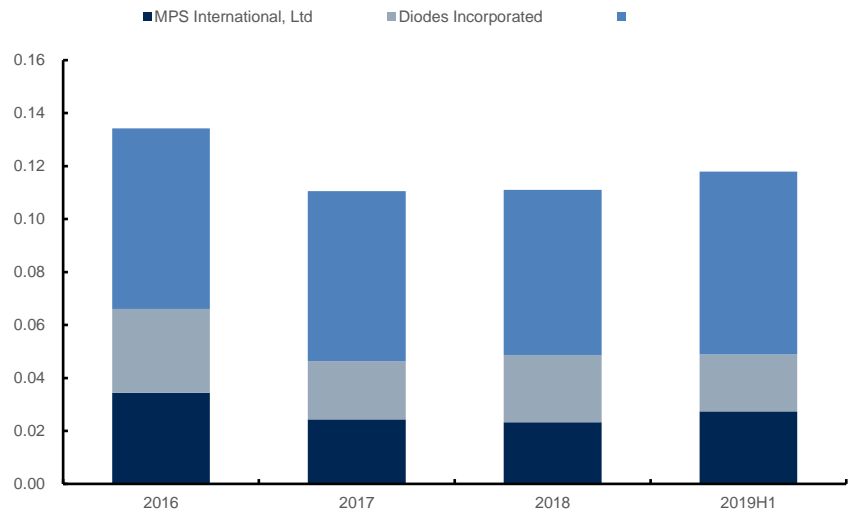

8 MPS

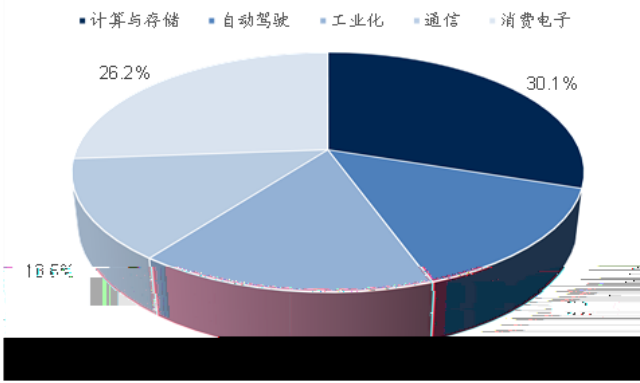

9 Diodes

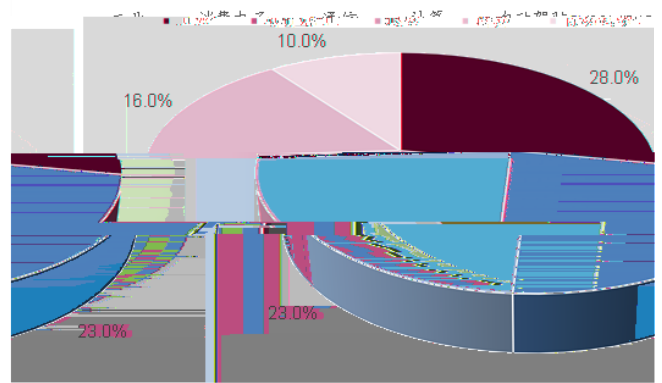



DC

AC

AC/AC

DC/AC

AC/DC

DC/DC

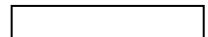

mosfet IGBT BJT

13

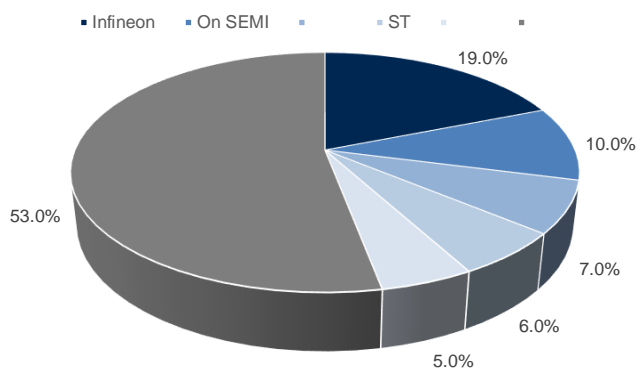

WSTS

14

5%

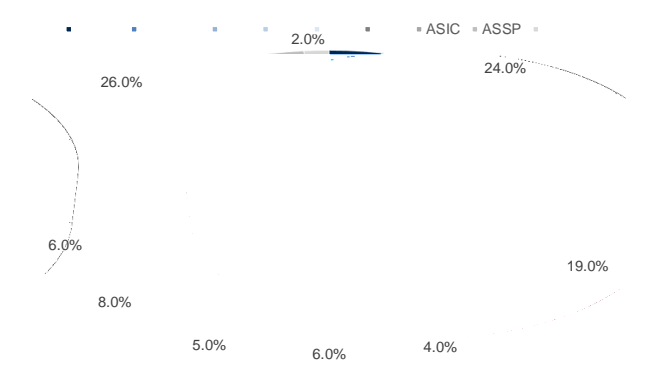

WSTS

IGBT MOSFET Infineon 27% 28% Renesas ST

IGBT MOSFET

15

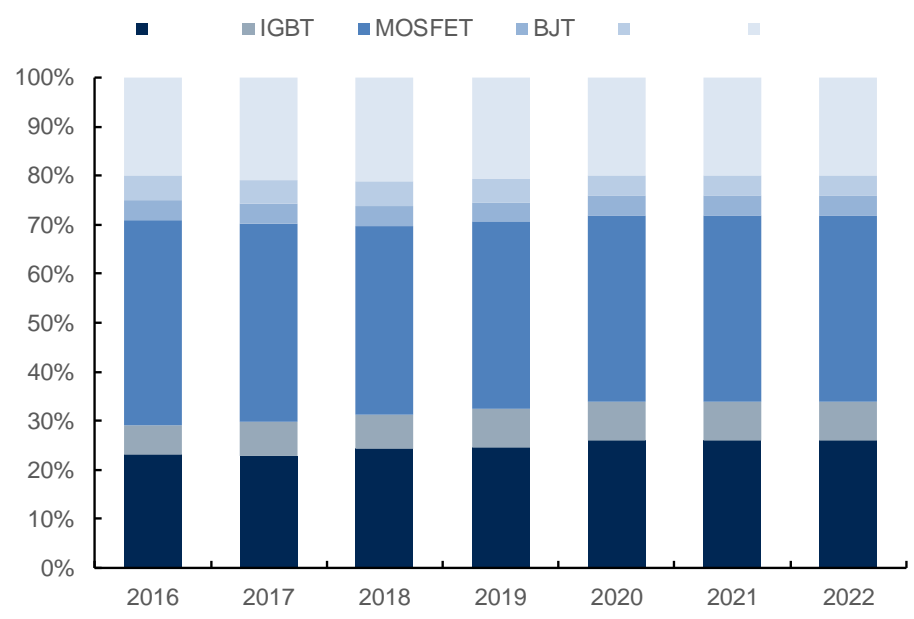

Yole

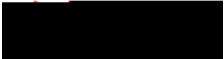

**16 IGBT**

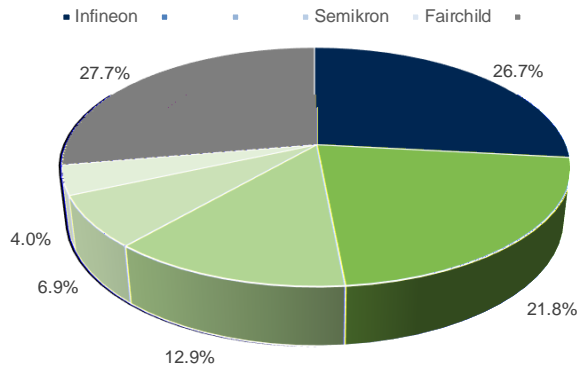

IHS

**17 MOSFET**

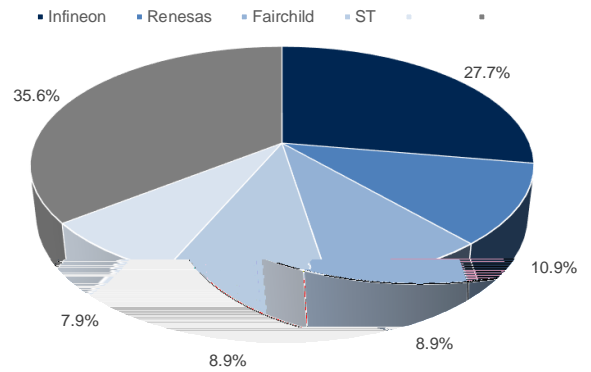

IHS

**Infineon**

1999

1999

2000

**18 Infineon**

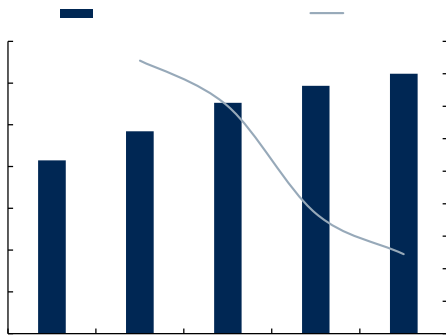

**19 Infineon**

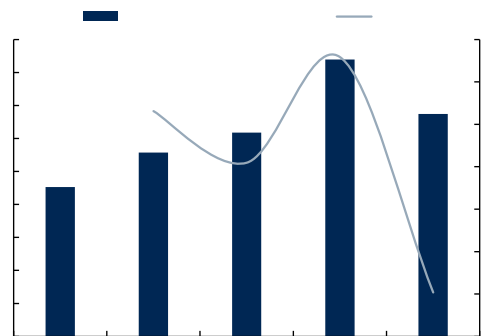

OptiMOS

CoolSiC

CoolGaN

CoolMOS

**20 Infineon CoolMOS MOSFET**

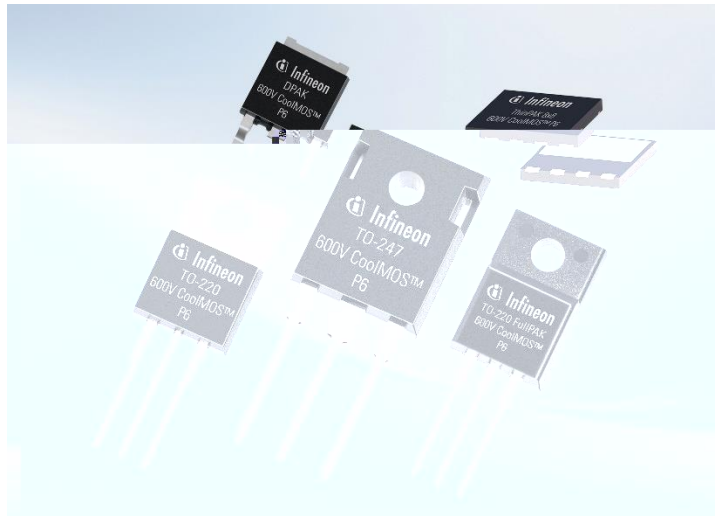

WSTS

**On SEMI**

On Semiconductor Corporation

1999

LED

**21 On Semi**

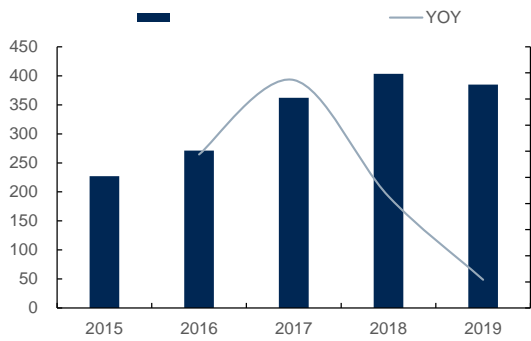

**22 On Semi**

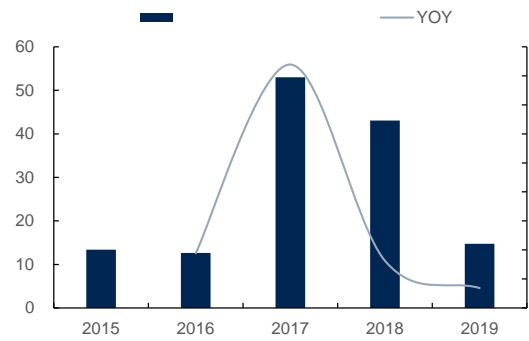

ASIC DSP

LED



23 On Semi 2020



24 On Semi

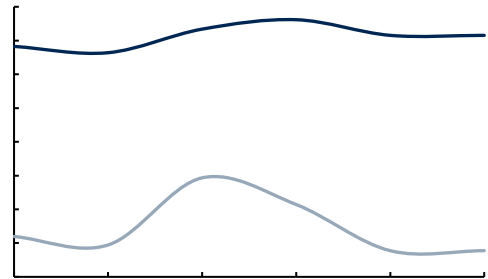

2015-2018

2019

2017

2020

50%

ST

ST

1987

SGS

Thomson

1998

5

SGS-

25

26

CMOS

FD-SOI

Bi-CMOS BCD (Bipolar, CMOS, DMOS)

RF-SOI ( )

MEMS

Silicon Carbide

VIPOWER



27 2019

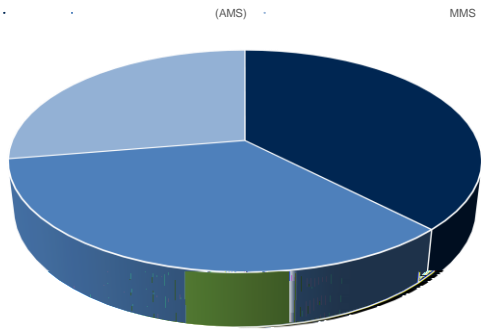

28

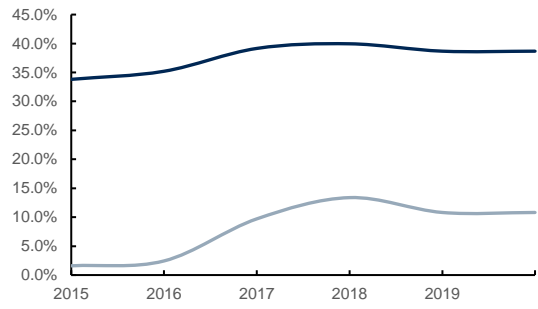

2019

2019

2015-2018  
2019

38%

5

DC / DC

29

5

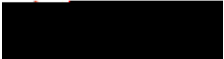

IGBT

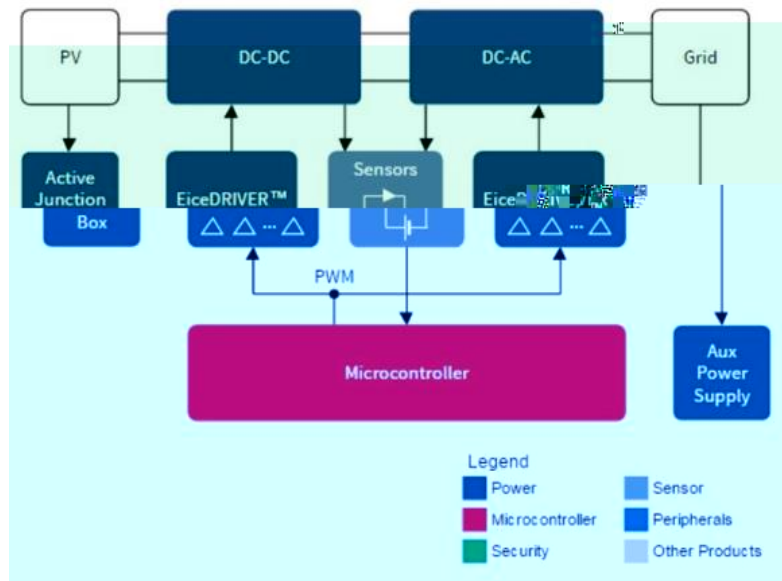



---

Infineon

IGBT MOSFET  
/

DC / AC  
;

Ü W ^ k ° Ü W ^ k ½ † Á ø

---

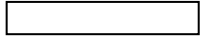

---

**PMIC- IC**

**PMIC- IC**





34 IC IC

比较项目	模拟IC	数字IC
信号传输	光, 声, 音, 速度, 温度等自然现象 连续信号	1或0非连续信号
技术层次	设计门槛高, 学习曲线10-15年	电脑辅助设计, 学习曲线3-5年
产品认证与生命周期	认证期长 (约1年以上), 但生命周期也长	认证周期短 (约3-个月), 但生命周期也短
替代性	低	高 (可用标准产品替代)
产品特点	少量多样	品种变化
数字信号编	与监控	逻辑运算处理与控制, 码与解码
产品应用	低但稳定	因时效性而变化
ASP (平均零售价格)		

IC

IC

IC

CMOS

IC

10  
CMOS

IC

IC

IC

IC  
IC

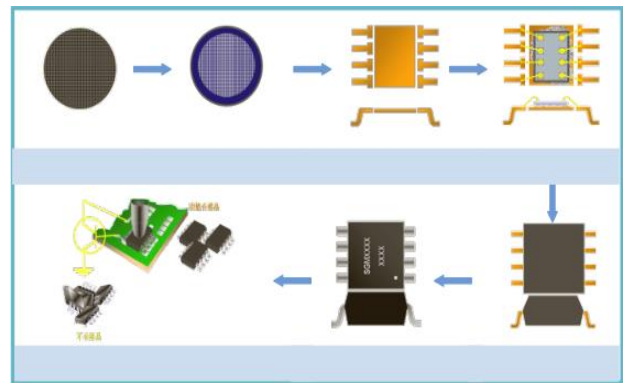
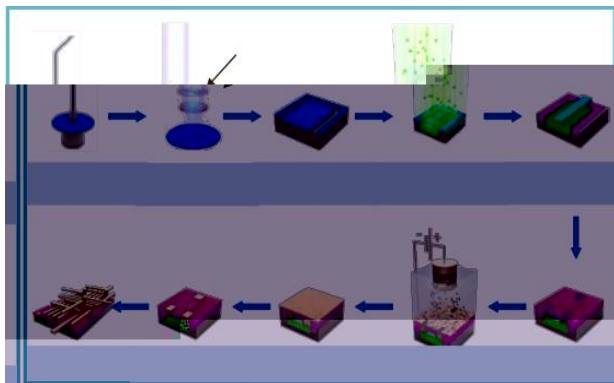
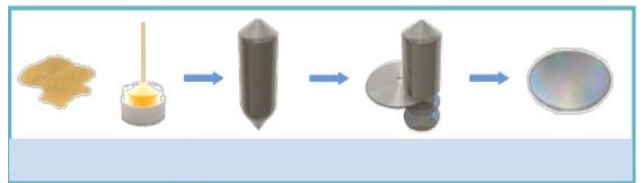
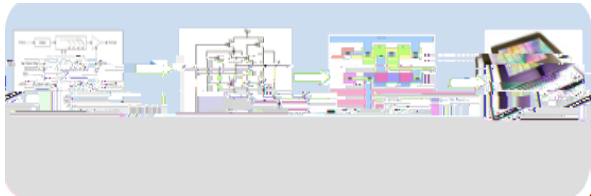
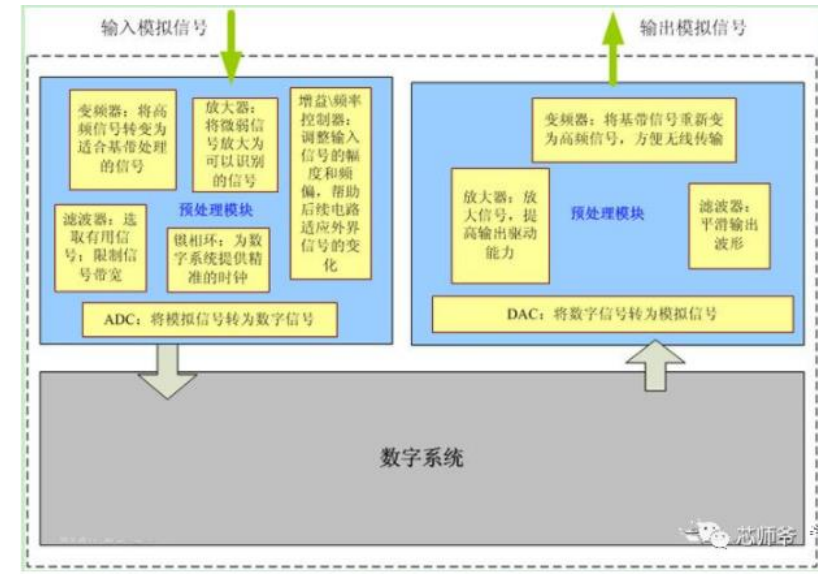



McClean Report

545 , 6.6% 2022 2017

748

40

17-22

41

IC

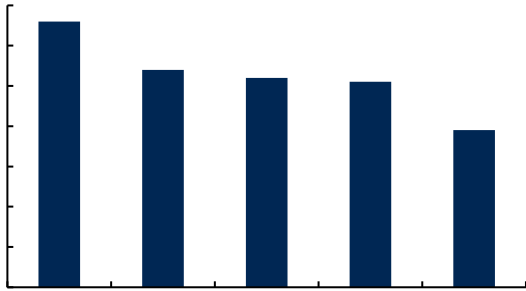

:ICinsights

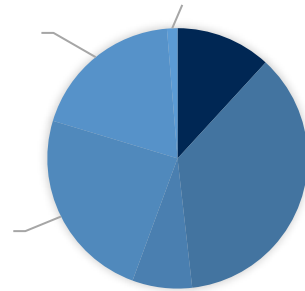

: ICinsights

( )

WSTS  
18/19/20  
IC

19

10.8%/-5%/5%

558



IC

IDM  
IDM

Foundry

2017

75.64%

IDM

42

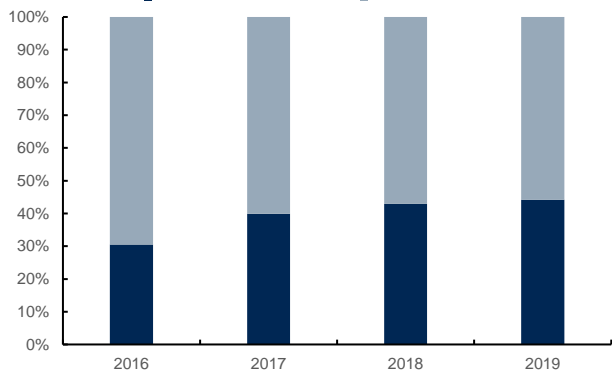

43

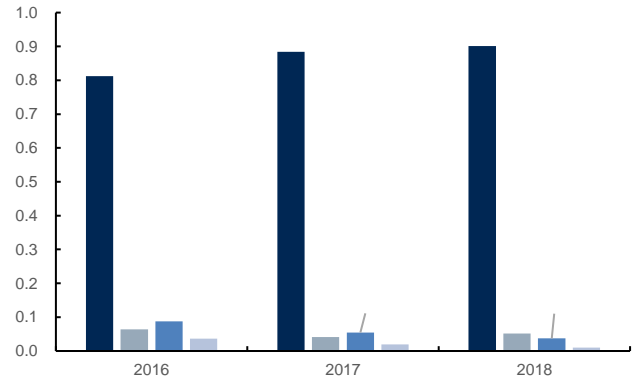

2016-2019  
7% 2017

2018

44

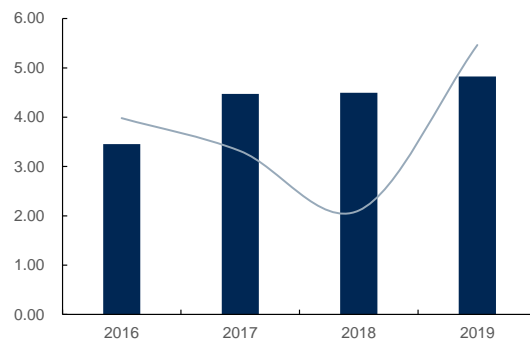

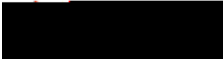

1173                      152                      SBD                      IC

BCD

**4546**

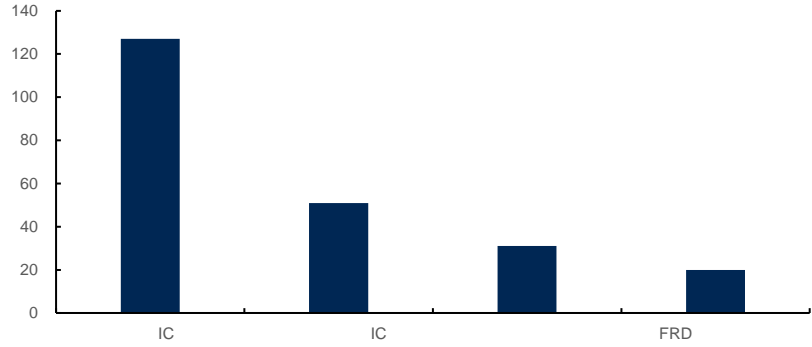

IDM                      +

3 6                      1 8  
1.0-0.11 m

8

IC

							2018
3 6	Analog	BCD	MEMS	DMOS	Power	Discrete	247
1 8	Advance	BCD	Analog	DMOS			73
1 8	MOS	MOS	MOS	SBD			60

Wind

8

1.6 /  
90nm

12

**47                      8**

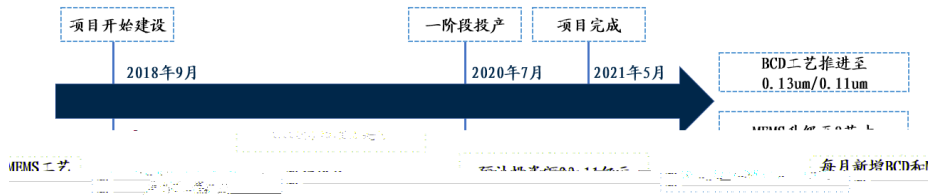



---

48

---

---

8		2016-2018	8	2017
	52.41%			
	8			
83.11%	99.01%			

---

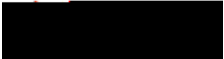

2019

2020Q2

2020	PC			8		IC
	MOSFET					
		IC	MOSFET			2020
	PC		OEM/ODM			
	IC	MOSFET				
INTEL		PC	Tiger Lake	10	SuperFin	
	10	15%	40Gbps	Thunderbolt 4	USB 4	
				CPU		
	PC			8		
IC		IC		IC	MOSFET	
			IDM			
		IC	MOSFET			

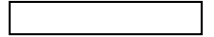





---

IHS Markit

MOSFET IGBT  
SiC

5

---



MOSFET IGBT 35% 2020 5 600-1200V SiC MOSFET IGBT 1.26 8 IPO 2018 9

58

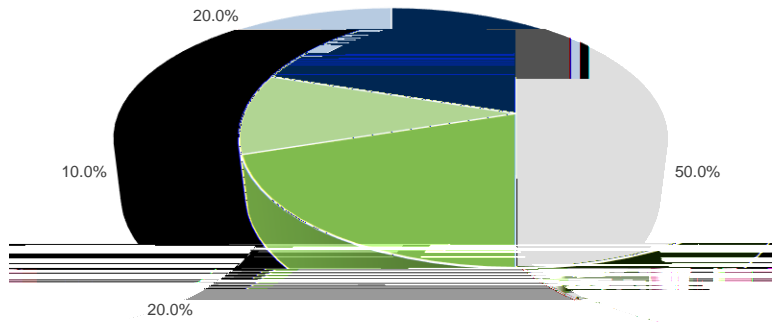

MEMS 16000 90nm 8 BCD 2020 7 50% 8 BCD 8 MEMS 8 12

59 8

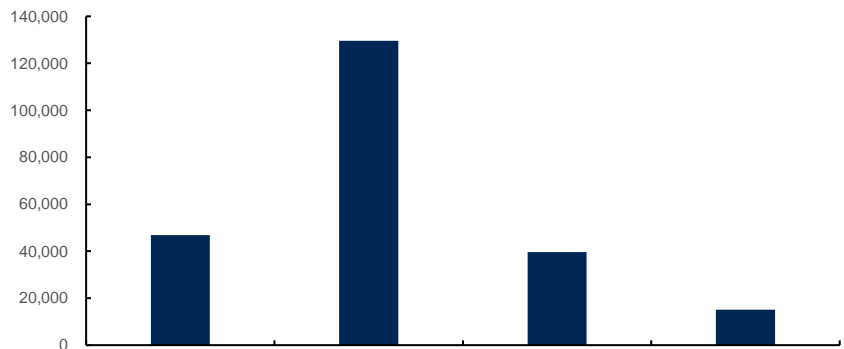



---

	2017	2018	2019	2020E	2021E	2022E
	22.9	26.6	25.0	29.1	33.4	38.5
YOY	78.9%	15.8%	-5.9%	16.4%	15.0%	15.0%
	19.4%	34.0%	29.4%	34.3%	33.9%	33.5%
	35.2	35.7	31.8	37.6	40.9	45.1
YOY	16.1%	1.5%	-10.9%	18.2%	8.6%	10.3%
	16.3%	18.6%	17.7%	20.2%	20.2%	20.3%
	58.1	62.3	56.8	66.7	74.3	83.5
	17.5%	25.2%	22.8%	26.3%	26.4%	26.4%

---



	2019	2020E	2021E	2022E
	6271	5743	6743	7512
	4690	4431	4967	5531
	85	66	67	75
	126	112	135	150
	374	377	146	161
	0	31	60	109
	11	(0)	0	0
	(72)	37	0	0
	(349)	(284)	0	0
	586	478	1368	1485
	5	28	0	0
	591	506	1368	1485
	53	(6)	0	0
	108	112	302	328
	429	401	1066	1157

Wind

20-22

10.7/11.6/13.0  
78.0-80.8

55/51/45X

	2017	2018	2019E	2020E	2021E
( )	6,271	5,743	7,417	8,263	9,288
(+/-%)	6.73%	-8.42%	29.15%	12.56%	13.64%
( )	429	401	1,173	1,273	1,426
(+/-%)	511.02%	-6.68%	192.60%	8.58%	11.97%
EPS	0.52	0.48	0.96	1.05	1.17
( )	6,271	5,743	6,743	7,512	8,444
(+/-%)	6.73%	-8.42%	17.41%	11.41%	12.40%
( )	429	401	1,066	1,157	1,296
(+/-%)	511.02%	-6.68%	166.00%	8.58%	11.97%
EPS( )	0.52	0.48	0.88	0.95	1.07
( )	6,271	5,743	6,068	6,761	7,600
(+/-%)	6.73%	-8.42%	5.67%	11.41%	12.40%
( )	429	401	959	1,042	1,166
(+/-%)	511.02%	-6.68%	139.40%	8.58%	11.97%
EPS	0.52	0.48	0.79	0.86	0.96
	830	830	1216	1216	1216

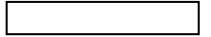

---

TV

---

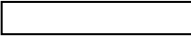



---

	2019	2020E	2021E	2022E		2019	2020E	2021E	2022E
--	------	-------	-------	-------	--	------	-------	-------	-------



---

---

